

Production Guide of Metal Wheel

For Automobile Parts

1. HMF (For Cylinder Block)

APPLICATION

Used for Cylinder Block

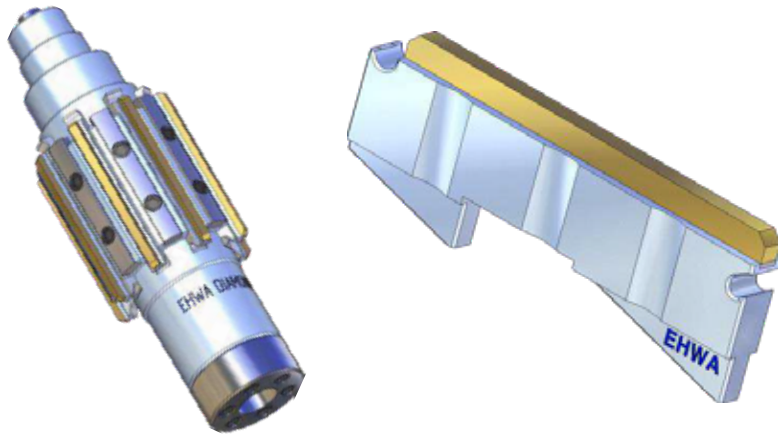

SHAPE OF TOOL



WORKPIECE / MACHINE

TYPE	GRIT SIZE	Length (mm)	BOND	Condition	Workpiece
Rough	#100 ~ #170	60 ~ 80	MS13, MJ1, MJ	Rz < 3 or 4 Rpk < 0.3 Rk, Rvk	FC25 (HB 187~241)
Finish	#325 ~ #400		MS12		
Platsu	#600 ~ #800		MJ, MH41		

2. HMF (For Cylinder Liner)

APPLICATION

Used for Cylinder Block

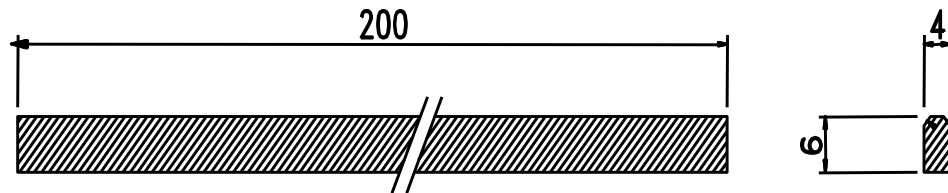

SHAPE OF TOOL



WORKPIECE(Cylinder Liner)

TYPE	GRIT SIZE	Length (mm)	BOND	Condition	Workpiece
Rough	#100 ~ #170	60 ~ 80	MS13, MJ1, MJ	Rz < 3 or 4 Rpk < 0.3 Rk, Rvk	FC25 (HB 187~241)
Finish	#325 ~ #400		MS12		
Platsu	#600 ~ #800		MJ, MH41		

3. HMF (For Pinion Gear)

APPLICATION

Used for Pinion Gear.

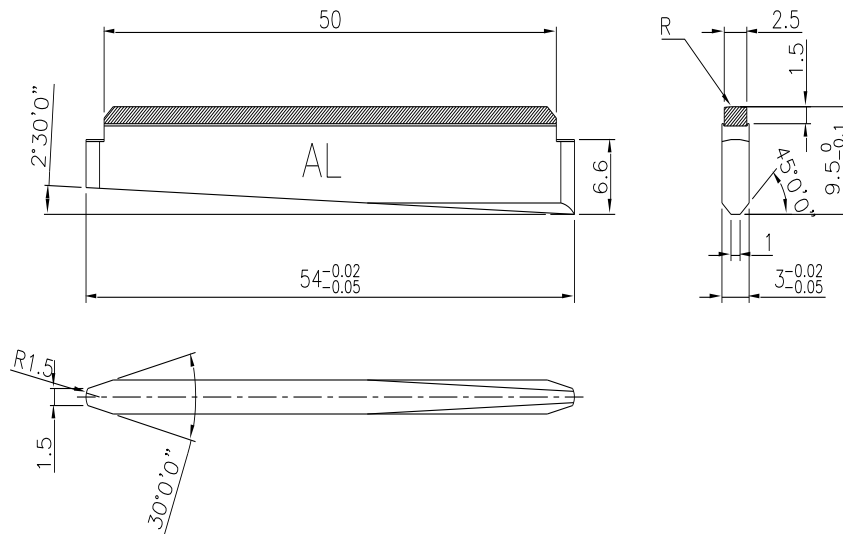

SHAPE OF TOOL



WORKPIECE / MACHINE

TYPE	GRIT SIZE	Length (mm)	BOND	Condition	Workpiece
Rough	#140 ~ #170	40 ~ 60	MH15, MB24	Ra < 0.25	SCM steel (HRc 59)
Finish	#800		MH17C	Roundness < 5μm Cylindricity < 5μm	

4. HMF (For Speed Gear)

APPLICATION

Used for Speed Gear.

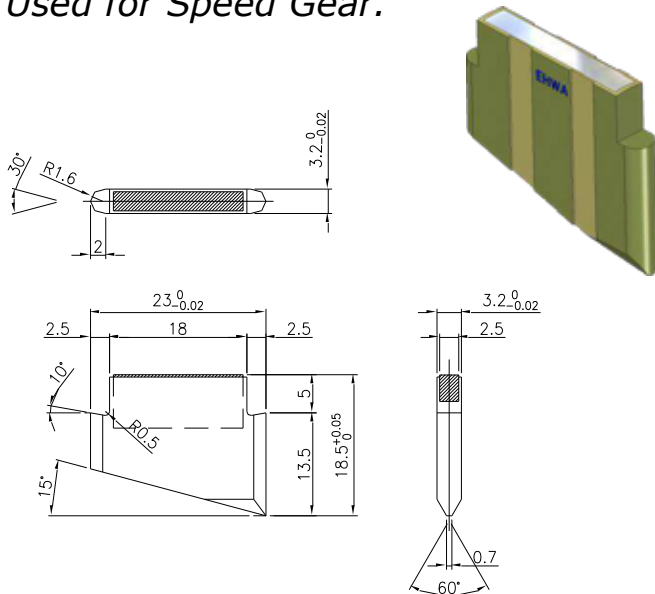

SHAPE OF TOOL



WORKPIECE(SPEED Gear) / MACHINE

TYPE	GRIT SIZE	Length (mm)	BOND	Condition	Workpiece
Rough	#140 ~ #170	40 ~ 60	ME4	Ra < 0.4	SCR steel (HRc 61)
Finish	#600		MH15, MS13	Cylindricity <20µm	

5. HMF (For DCT Gear)

APPLICATION

Used for DCT Gear

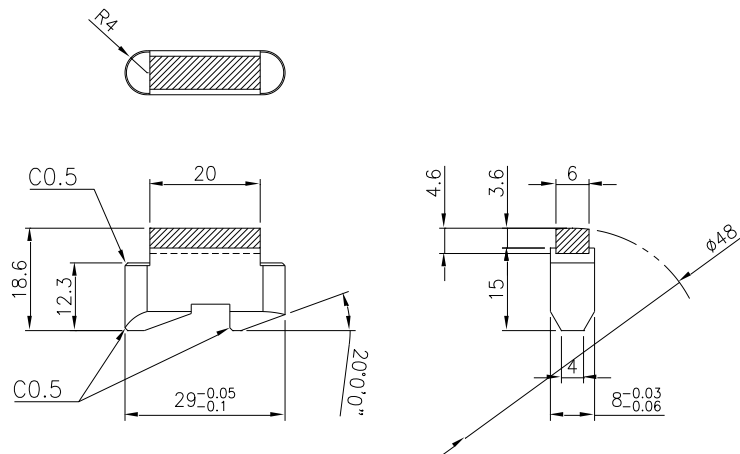

SHAPE OF TOOL



WORKPIECE (Speed Gear)

TYPE	GRIT SIZE	Length (mm)	BOND	Condition	Workpiece
Rough	#140 ~ #170	40 ~ 60	MB24	Ra < 0.4 or 0.32	SCM steel (Hrc 65)
Finish	#600 ~ #800		MH15, MH41	Roundness < 5 μ m Cylindricity < 10 μ m	

6. HMF (For Sleeve Gear)

APPLICATION

Used for Sleeve Gear

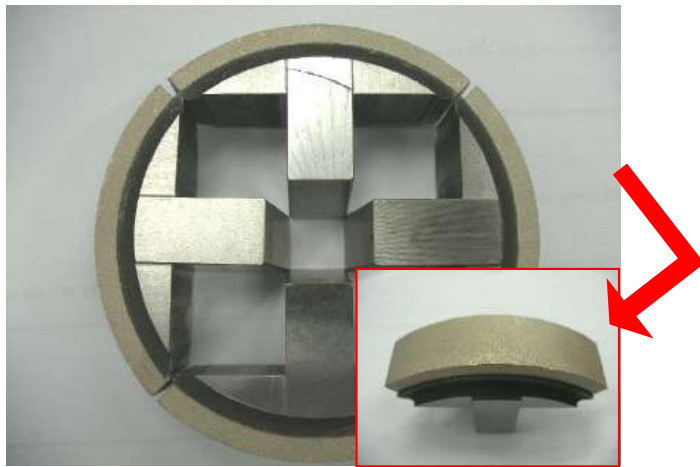

SHAPE OF TOOL

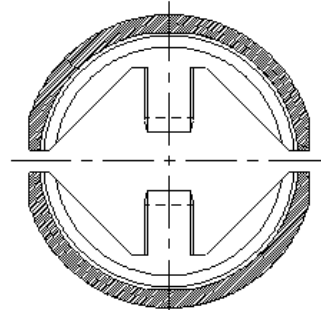

2P-TYPE

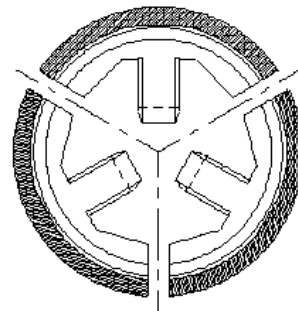

3P-TYPE



WORKPIECE / MACHINE

TYPE	GRIT SIZE	Length (mm)	BOND	Condition	Workpiece
Rough	#270	70.5D	MB33	Ra < 0.4	SCM steel (HB 160 ~ 187)
Finish	#400 ~ #500		MS3	Roundness < 30μm	

7. HMF (For Con-Rod)

APPLICATION

Used for Connection-Rod.

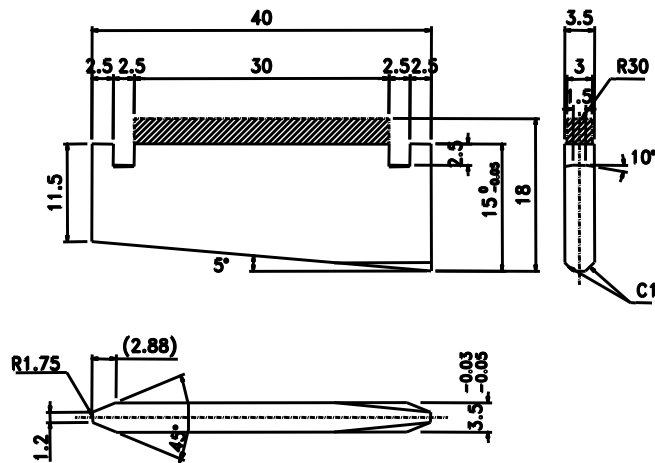

SHAPE OF TOOL



WORKPIECE / MACHINE

TYPE	GRIT SIZE	Length (mm)	BOND	Condition	Workpiece
A TYPE	#325	20~40L	MS12, MB24	Ra < 0.8	FC (HB 100~110)
B TYPE	#400 ~ #500		MJ1, MH41		

8. HMF (For Rocker Arm)

APPLICATION

Used for Rocker Arm

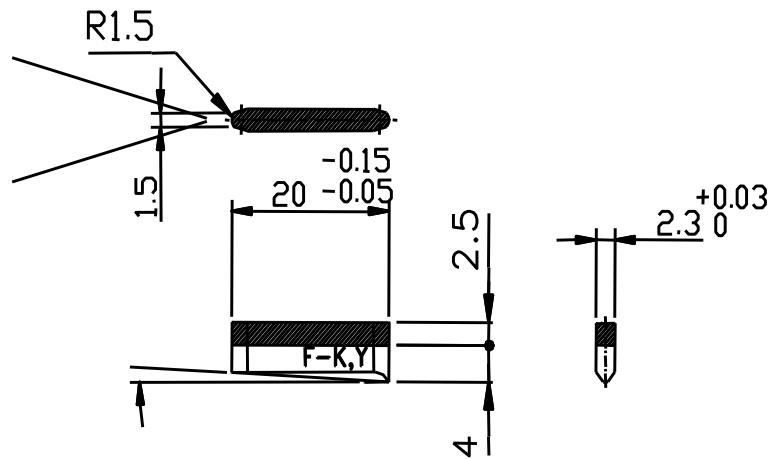

SHAPE OF TOOL

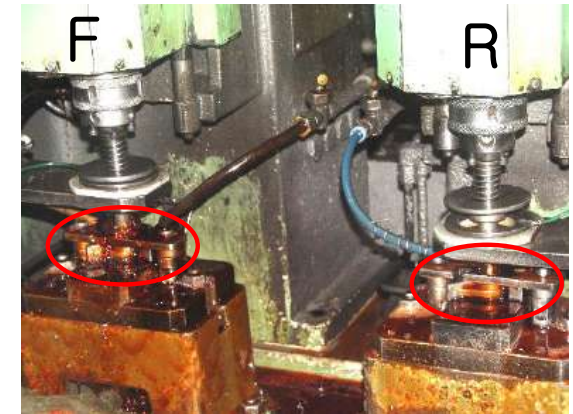

WORKPIECE(Rocker Arm)

TYPE	GRIT SIZE	Length (mm)	BOND	Condition	Workpiece
ROUGH	#120 ~ #140	20L-2.3W-2.5X	MS12	Rs < 3.2	SCM steel
FINISH	#500		MS3		

9. HMF (For Clutch Cylinder)

APPLICATION

Used for Clutch Cylinder.

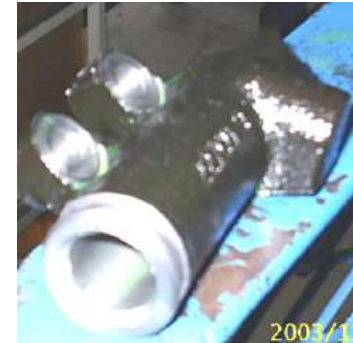
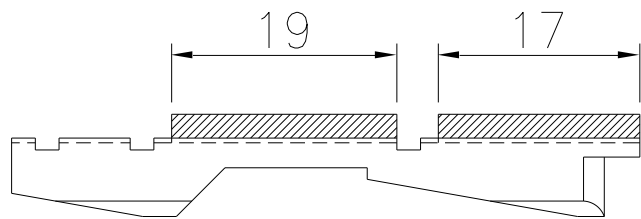

SHAPE OF TOOL

WORKPIECE(Clutch Cylinder)

TYPE	GRIT SIZE	Length (mm)	BOND	Condition	Workpiece
ROUGH	#400	17L-2.5W-2.3X 19L-2.5W-2.3X	MS12		FC, FCD, AL Alloy.
FINISH	#800		MS3		